



## APPROVED MINUTES

### January 15, 2026, Standards Committee Meeting

March 26, 2026

TO: Standards Committee

FROM: Scott Trammell, Secretary

RE: Minutes from January 15, 2026, Standards Committee Meeting

The Standards Committee meeting was called to order by Mr. Pankow, Chair, at 09:01 a.m. on Thursday, January 15, and was held virtually via *Teams* (Microsoft application). The meeting was adjourned at 09:47 a.m.

The following committee members were in attendance:

Pankow, Gregory, Chairman, Director, Construction Management  
Boruff, David Traffic Engineering  
Dave, Kumar, Pavement Engineering  
Golkhajeh, Jaffar, Asset Management  
Koch, Mike, District Construction, Fort Wayne District  
Novak, Joseph, Construction Management  
Orton, Mark, Highway Engineering  
Pelz, Kurt, Construction Technical Support  
Reilman, Jim, Materials and Tests  
White, Peter, Bridge Engineering  
Wooden, John, Contract Administration  
\*Proxy for Rearick, Anne

Also, the following attendees were present:

Awwad, Nathan E., INDOT  
Barnes, Tracy, INDOT  
Blanchard, Jacob, INDOT  
Borgmann, Kathy, INDOT  
Chandore, Gauri, INDOT  
Delp, Patrick, INDOT

Kachler, Mischa, INDOT  
Mouser, Elizabeth, INDOT  
Mueller, Bart, INDOT  
Nunley, Cindy, INDOT  
Podorvanova, Lana, INDOT  
Powell, Traci M, INDOT

Duncan, Thomas, FHWA  
Emmert, Rhonda, INDOT  
Fox, Gary A, INDOT  
Galetka, Jason, INDOT  
Gulinson, Brent, ISP  
Harding, Matthew, INDOT  
Harris, Tom, INDOT  
Hauser, Derrick, INDOT  
Jacobs, David L, INDOT

Ranck, Amanda, INDOT  
Reedy, Joseph, INDOT  
Reese, Sarah, INDOT  
Siddiki, Nayyar Zia, INDOT  
Smith, Charles, INDOT  
Trammell, Scott, INDOT  
Waterfall, Edward, Rinker Pipe  
Wortkoetter, Andrew, INDOT

The following items were discussed:

**A. GENERAL BUSINESS**

OLD BUSINESS (No items were listed)

NEW BUSINESS

Approval of the Minutes from the [December 19, 2025](#) meeting

Mr. Pankow requested a motion to approve the Minutes from the December 19, 2025 meeting.

Motion: Mr. Reilman  
Second: Mr. Pelz  
Ayes: 10  
Nays: 0

ACTION: PASSED AS SUBMITTED

**B. CONCEPTUAL PROPOSAL**

(No items were listed)

**C. STANDARD SPECIFICATIONS, SPECIAL PROVISIONS, AND STANDARD DRAWINGS PROPOSAL**

OLD BUSINESS (No items were listed)

NEW BUSINESS

[Item No. 1](#) [Mr. Novak](#) [pg. 4](#)

2026 Standard Specifications:  
108.01

Subletting of Contract

ACTION:

PASSED AS REVISED

---

Item No. 2 Mr. Pelz pg. 9  
Recurring Special Provision:  
801-R-672 LAW ENFORCEMENT OFFICER FOR WORK  
ZONE SAFETY  
  
ACTION: PASSED AS REVISED

Item No. 3 Mr. White pg. 23  
Standard Drawings:  
E 726-BEBP series BRIDGE ELASTOMERIC BEARING PADS  
  
ACTION: PASSED AS SUBMITTED

cc: Committee Members  
FHWA  
ICI

PROPOSAL TO STANDARDS COMMITTEE

PROBLEM(S) ENCOUNTERED: Changes related to the DBE program that have raised questions about the permissibility to have supplemental trucking in certain cases.

PROPOSED SOLUTION: Provide clear contract requirements on the permissibility to use supplemental trucking regardless of DBE status.

APPLICABLE STANDARD SPECIFICATIONS: 108.01

APPLICABLE STANDARD DRAWING: n/a

APPLICABLE DESIGN MANUAL CHAPTER: n/a

APPLICABLE SECTION OF GIFE: Section 2.7.3

APPLICABLE RECURRING SPECIAL PROVISION OR PLAN DETAILS: n/a

PAY ITEMS AFFECTED: n/a

APPLICABLE SUB-COMMITTEE ENDORSEMENT: Ad hoc Joe Novak and District CCO's

IF APPROVED AS RECURRING SPECIAL PROVISION OR PLAN DETAILS, PROPOSED BASIS FOR USE: No RSP. Revision to incorporate into 2028 Standard Specifications only.

IMPACT ANALYSIS (attach report):

Submitted By: Joe Novak

Title: State Construction Engineer

Division: Construction Management

E-mail: jnovak@indot.in.gov

Date: 10/24/25

IMPACT ANALYSIS REPORT CHECKLIST

*Explain the business case as to why this item should be presented to the Standards Committee for approval. Answer the following questions with Yes, No or N/A.*

Does this item appear in any other specification sections? 103.01

Will approval of this item affect the Qualified Products List (QPL)? no

Will this proposal improve:

Construction costs? no

Construction time? no

Customer satisfaction? no

Congestion/travel time? no

Ride quality? no

Will this proposal reduce operational costs or maintenance effort? no

Will this item improve safety:

For motorists? no

For construction workers? no

Will this proposal improve quality for:

Construction procedures/processes? yes

Asset preservation? no

Design process? no

Will this change provide the contractor more flexibility? yes

Will this proposal provide clarification for the Contractor and field personnel? yes

Can this item improve/reduce the number of potential change orders? no

Is this proposal needed for compliance with:

Federal or State regulations? no

AASHTO or other design code? no

Is this item editorial? no

Provide any further information as to why this proposal should be placed on the Standards Committee meeting Agenda:

REVISION TO 2026 STANDARD SPECIFICATIONS

SECTION 108 – PROSECUTION AND PROGRESS

108.01 Subletting of Contract

The Standard Specifications are revised as follows:

SECTION 108, BEGIN LINE 3, DELETE AND INSERT AS FOLLOWS:

**108.01 Subletting of Contract**

The contract, contracts, or portions thereof; or the right, title, or interest therein shall not be sublet, sold, transferred, assigned, or otherwise disposed of without written consent. In case such consent is given, the Contractor will be allowed to sublet a portion thereof, but shall perform with its own organization, work amounting to not less than 50% of the original or revised contract amount, whichever is less. All items designated in the contract as specialty items may be performed by subcontract. The cost of such specialty items so performed by subcontracts may be deducted from the total cost before computing the amount of work required to be performed by the Contractor with its own organization. No subcontracts or transfer of contracts will release the Contractor of liability under the contract and bonds. Approved subcontractors will not be allowed to further subcontract their work.

Unless the Department provides written consent, the Contractor shall not be entitled to any payment for subcontracted work or materials unless it is performed or supplied by a subcontractor approved on the contract prior to the work being performed.

The minimum wage for labor as stated in the Proposal shall apply to all labor performed on all work sublet, assigned, or otherwise disposed of in any way.

*With the approval of the Department, the Contractor or subcontractor may enter into leases or rental agreements for equipment with operators or trucks with drivers. The Contractor or subcontractor may also enter into such agreements with trucking companies that intend to provide supplemental trucks with or without drivers in addition to its own. These primary trucking companies that serve as a lessee may enter into leases for supplemental trucking lessors. Supplemental trucking lessors may shall not further supplement. The Department may limit the number of agreements a trucking company may be a party to per contract. All trucking companies, lessees, and lessors must shall be as approved by the Department prior to use. All general or standing agreements must shall contain contract specific addendums. All such agreements and addendums shall be provided as a condition of approval. Failure to comply with these provisions may result in the discontinued allowance of supplemental trucking. When certified payrolls are required, they shall be submitted for all such equipment operators and truck drivers who perform work. This payroll shall verify that these employees have been paid not less than the predetermined wage rate set out elsewhere in the contract for the classification of work performed.*

The subcontractor shall be in accordance with the requirements of 105 IAC 11-2-10, Subcontractors.

The Contractor shall submit payment records through the Department's Subcontractor Payment Tracking System (<http://itap.indot.in.gov>) of all payments made to

REVISION TO 2026 STANDARD SPECIFICATIONS

---

SECTION 108 – PROSECUTION AND PROGRESS

108.01 Subletting of Contract

subcontractors and DBE, MBE, WBE, and IVOSB firms approved by the Department. Reports shall be submitted no later than 10 days after the end of each month in which a subcontractor is paid for work on the contract. Reports shall include any release of retainage payments made to subcontractors.

All subcontractors and DBE, MBE, WBE, and IVOSB firms approved by the Department shall verify all payments made to them through the Department's Subcontractor Payment Tracking System (<http://itap.indot.in.gov>). All payments received for work on the contract shall be verified no later than 20 days after the end of the month in which payment was received.

APPROVED MINUTES

COMMENTS AND ACTION

108.01 Subletting of Contract

DISCUSSION:

This item was introduced and presented by Mr. Novak who stated that changes related to the DBE program have raised questions about the permissibility to have supplemental trucking in certain cases.

Mr. Novak proposed to provide clear contract requirements on the permissibility to use supplemental trucking regardless of DBE status.

Mr. Koch expressed concern with some of the language in the fourth paragraph of 108.01. Mr. Novak concurred with the proposed revisions and they, along with some minor editorial revisions, are as shown above.

Mr. Novak proposed that this item be accepted as revised. Mr. Novak stated that an RSP is not necessary, and the release of the Construction memo will suffice.

There was no further discussion and this item passed as revised.

<p>Motion: Mr. Novak          Second: Mr. Koch          Ayes: 10          Nays: 0          FHWA Approval: <u>YES</u></p>	<p><u>Action:</u>  <input type="checkbox"/> Passed as Submitted  <input checked="" type="checkbox"/> Passed as Revised  <input type="checkbox"/> Withdrawn</p>
<p>2026 Standard Specifications Sections:          108.01, pg. 86 - 87.</p>	<p><input checked="" type="checkbox"/> 2028 Standard Specifications  <input type="checkbox"/> Revise Pay Items List  <input type="checkbox"/> Notification to Designers if change is <u>not</u>          addressed by RSP</p>
<p>Recurring Special Provisions or Plan          Details:          NONE</p>	<p><input type="checkbox"/> Create RSP (No. __)          Effective:</p>
<p>Standard Drawing affected:          NONE</p>	<p><input type="checkbox"/> Revise RSP (No. __)          Effective:</p>
<p>Design Manual Chapter:          NONE</p>	<p><input type="checkbox"/> Standard Drawing          Effective:</p>
<p>GIFE Section:          NONE</p>	<p><input type="checkbox"/> Create RPD (No. __)          Effective:</p>
	<p><input checked="" type="checkbox"/> GIFE Update (Section 2)  <input type="checkbox"/> Frequency Manual Update  <input type="checkbox"/> AWP Update</p>

PROPOSAL TO STANDARDS COMMITTEE

PROBLEM(S) ENCOUNTERED: With a history of problematic implementation of Law Enforcement Officers (LEOs) on active Department contracts, there was a need to revise the current RSP 801-R-672 to help provide guidance and clarity.

PROPOSED SOLUTION: New procedures and training methods will help provide officers for Department contracts that have appropriate training. The new process will also help the LEO's appointing authority with an acknowledgment of their officer's work area and use of police vehicles during Department operational shifts.

APPLICABLE STANDARD SPECIFICATIONS: N/A

APPLICABLE STANDARD DRAWING: N/A

APPLICABLE DESIGN MANUAL CHAPTER: N/A

APPLICABLE SECTION OF GIFE: Section 26.2

APPLICABLE RECURRING SPECIAL PROVISION OR PLAN DETAILS: RSP 801-R-672

PAY ITEMS AFFECTED: Pay Item 801-12324, Law Enforcement Officer

APPLICABLE SUB-COMMITTEE ENDORSEMENT: Ad hoc committee: John McGregor, Mischa Kachler, Brent Gulinson (ISP), Marjorie Millman, Roland Fegan, Sarah Reese, Kurt Pelz

IF APPROVED AS RECURRING SPECIAL PROVISION OR PLAN DETAILS, PROPOSED BASIS FOR USE: Same as current: Required for all contracts identified **as significant** in relation to work zone impacts in accordance with IDM Section 503-2.02. For contracts identified **as non-significant**, as determined necessary by the **District Construction** [pay item: **801-12324**].

IMPACT ANALYSIS (attach report): Yes

Submitted By: Kurt Pelz

Title: Technical Support Engineer

Division: Construction Management

E-mail: kpelz@indot.in.gov

Date: 12/15/2025

IMPACT ANALYSIS REPORT CHECKLIST

*Explain the business case as to why this item should be presented to the Standards Committee for approval. Answer the following questions with Yes, No or N/A.*

Does this item appear in any other specification sections? No

Will approval of this item affect the Qualified Products List (QPL)? No

Will this proposal improve:

Construction costs? No

Construction time? No

Customer satisfaction? Yes

Congestion/travel time? Yes

Ride quality? No

Will this proposal reduce operational costs or maintenance effort? No

Will this item improve safety:

For motorists? Yes

For construction workers? Yes

Will this proposal improve quality for:

Construction procedures/processes? Yes

Asset preservation? No

Design process? No

Will this change provide the contractor more flexibility? Yes

Will this proposal provide clarification for the Contractor and field personnel? Yes

Can this item improve/reduce the number of potential change orders? Yes

Is this proposal needed for compliance with:

Federal or State regulations? No

AASHTO or other design code? No

Is this item editorial? No

Provide any further information as to why this proposal should be placed on the Standards Committee meeting Agenda: Improvement in safety for field personnel and the traveling public. Aid in the traffic flow through an active contract using off-duty law enforcement officers by focusing on queue protection, reducing aggressive driving through enforcement, and patrolling the site.

REVISION TO SPECIAL PROVISION

801-R-672 LAW ENFORCEMENT OFFICER FOR WORK ZONE SAFETY

801-R-672 LAW ENFORCEMENT OFFICER FOR WORK ZONE SAFETY

(Revised 09-16-21)

**Description**

This work shall consist of providing a Law Enforcement Officer, LEO, to assist with the safe, efficient, and orderly movement of traffic. ~~LEOs are to~~ shall be used, along with properly utilized and implemented maintenance of traffic devices, ~~and~~ to enhance ~~worker~~ safety during construction activities. The primary functions of LEO efforts within work zones shall be to provide queue protection, reduce aggressive driving through focused enforcement, and patrol the site. Any accepted and utilized LEO shall be in accordance with 103.05 ~~and 108.01~~. If a private company is used, the Contractor shall enter into a subcontract agreement with the private company in accordance with 108.01. A subcontract agreement will not be required if the LEO is obtained directly from a law enforcement agency.

**Materials**

Materials shall be in accordance with 801.02 and as described herein.

**Construction Requirements**

~~Traffic control and work zone safety shall be in accordance with 801 and the MUTCD. Utilization of the LEO may include providing advanced warning for:~~

- ~~1. Maintenance of traffic set up, tear down, and substantial traffic shifts.~~
- ~~2. New lane closure arrangements initiated for long term lane closures or shifts.~~
- ~~3. The first and last day of major changes in traffic control set up, and queue protection.~~
- ~~4. Other unique contract uses specified to enhance overall worker and motorist safety.~~

~~Use of a LEO by the Contractor will not be allowed at contract cost without prior approval by the Engineer. The LEO shall not be used where the MUTCD specifies flaggers are to be used.~~

**LEO Personnel Requirements**

The LEO shall be:

- ~~a) an off-duty, non-Indiana State Police Law Enforcement Officer in full police uniform, and~~
- ~~b) a graduate of an Indiana approved Law Enforcement Academy, and~~
- ~~c) a police officer or deputy actively employed by a police agency in Indiana.~~

REVISION TO SPECIAL PROVISION

801-R-672 LAW ENFORCEMENT OFFICER FOR WORK ZONE SAFETY

~~In accordance with IC 8-23-2-15(b), the duties of a police officer hired under this special provision shall:~~

- ~~1. Be limited to those duties that the police officer normally performs while on active duty; and~~
- ~~2. Not include the duties of a
  - ~~a. Flagman; or~~
  - ~~b. Security Officer.~~~~

**Equipment**

~~The LEO shall use a marked police vehicle with emergency flashing lights and complete markings of the appropriate law enforcement agency. At a minimum, the marked police vehicle shall be equipped with an 800 MHz radio/portable radio that contains the local and statewide mutual aid channels within the area the LEO is working.~~

~~When outside of the marked police vehicle, the LEO shall wear the correct ANSI certified high visibility safety apparel provided by their agency.~~

**Operation**

~~The Contractor shall be responsible for securing the services of the LEO with the appropriate agency and communicating the intentions of the plans with respect to the duties of the LEO as approved by the Engineer. The Contractor and the LEO shall follow the standards for placement of the LEO in work zones set forth by the NCHRP Report 746.~~

~~The Contractor shall establish direct communication with the LEO prior to the start of their shift. The method of communication shall be at the discretion of the Contractor and may include the exchange of mobile telephone numbers or dedicated communication devices, such as mobile phones and walkie talkies. The Contractor may provide the LEO with dedicated communication devices. Contractor provided dedicated communication devices shall be returned to the Contractor at the end of the LEO's shift.~~

**Training**

~~Training for the LEO, the Contractor, and the Engineer will be conducted in two parts. Both parts shall be completed prior to involvement in traffic maintenance operations on the contract. The first part of the training will be web based and provide concepts and reasoning for the use of LEOs on Department contracts. The second part of the training will provide supplementary guidance for LEOs working within Department work zones.~~

**Part 1**

~~Prior to involvement in maintenance of traffic operations, the LEO, at least one representative of the Contractor who will be onsite when the LEO is present, and the Engineer shall complete the Department's web based "Law Enforcement Officers in INDOT Work Zones Training". The training consists of three modules and is available on the Work Zone Safety website located at~~

~~<https://www.in.gov/indot/safety/work-zone-safety/law-enforcement-officers-for-work-zone-safety/>.~~

REVISION TO SPECIAL PROVISION

801-R-672 LAW ENFORCEMENT OFFICER FOR WORK ZONE SAFETY

**~~Part 2~~**

~~The LEO, the Contractor, and the Engineer are also required to review and agree to adhere to the requirements contained in Department specific training entitled "Instructions and Procedures For Non-ISP Law Enforcement Officers When Working in INDOT Work Zones". The training document is available on the Work Zone Safety Website located at <https://www.in.gov/indot/safety/work-zone-safety/law-enforcement-officers-for-work-zone-safety/>.~~

~~All individuals completing Parts 1 and 2 training shall sign the signature page located at the end of the Part 2 training document. By signing, individuals shall be confirming they have completed Parts 1 and 2 of the law enforcement training requirements.~~

~~The Part 2 training instruction document, any training notes, and the signature document will be retained within the contract files.~~

**~~Engineer Responsibilities~~**

~~The activities of the LEO are subject to the authority and direction of the Engineer, in accordance with 105 and 108, and are limited to the activities associated with the contract work zone. The Contractor's choice of duties and placement of the LEO on any given work shift are subject to approval by the Engineer. The Engineer will have no authority over the LEO when the LEO is acting in a law enforcement agency capacity. The Engineer may direct the LEO to perform enforcement and other unspecified activities to encourage motorists to respect the work zone. Other unspecified activities of the LEO will not be allowed without prior approval of the Engineer.~~

**~~Contractor Responsibilities~~**

~~The Contractor shall be responsible for the LEO's duties and placement. The Contractor shall inform the Engineer of all planned LEO activities, any issues that may arise, and when the LEO leaves the construction site for any reason. Duties and placement of the LEO are subject to approval by the Engineer. The Contractor shall verify that the LEO remains at the construction site for the entire duration of their shift and reports back at the end of the shift unless directed otherwise by the Engineer.~~

**~~LEO Responsibilities~~**

~~The LEO shall report to the Contractor prior to the start of the shift in order to receive instructions regarding specific work assignments. The LEO shall remain at the construction site for the entire duration of their shift. If the LEO has completed the duties described above and still has time remaining on their shift, the LEO may be asked to patrol through the work zone, with flashing lights off, or be placed at a location to deter motorists from speeding or following too closely. At the end of the shift, the LEO shall notify the Contractor before leaving the construction site.~~

~~All LEOs shall follow the procedures for infraction and ordinance violation enforcement established by IC 9-21-5-11 while working within the work zone. This shall include issuing citations for infractions or detaining individuals in violation of traffic laws when and where appropriate.~~

REVISION TO SPECIAL PROVISION

801-R-672 LAW ENFORCEMENT OFFICER FOR WORK ZONE SAFETY

~~The LEOs shall not forgo their traffic control responsibilities to apprehend motorists for routine traffic violations, except that enforcement action is encouraged to enhance motorist compliance and increase driver awareness. If a motorist's actions are considered reckless or endangering to the workers or to the motoring public, then pursuit of the motorist is appropriate. LEOs shall also respond to any incident or situation involving public safety, including but not limited to crashes, near or within the contract limits to ensure the safety of the parties involved, and the motoring public. When it is necessary for the LEO to leave the construction site under these circumstances, the LEO shall notify the Contractor as soon as reasonably possible.~~

**Construction Requirements**

Traffic control and work zone safety shall be in accordance with 801 and the IMUTCD. The use of a LEO shall not be a substitute for the appropriate implementation of temporary traffic control devices in accordance with the IMUTCD and CFR 23 630.1108(d).

~~The Contractor shall schedule pre-shift meetings shall to be held on-site and involve the LEO, all Contractor representatives involved in LEO placement, and appropriate Department field staff. The intent of the pre-shift meeting shall be to exchange contact information, discuss specific problematic situations of the work zone, develop solutions to those situations, and focus on other pertinent aspects of the maintenance of traffic plan for the jobsite involving the LEO. If requested in writing, pre-shift meeting requirements may be waived in part or in full subject to the acceptance of the Engineer.~~

A LEO used on a project shall concentrate on:

- a) queue protection,
- b) focused enforcement to reduce aggressive driving, and
- c) patrolling the site.

A LEO may also be directed to provide advance warning on the project for:

- a) maintenance of traffic set ups, tear downs, and substantial traffic shifts when there are significant risks to workers and the traveling public,
- b) new lane closure arrangements initiated for long-term lane closures or shifts,
- c) the first and last days of major changes in traffic control set ups, and
- d) other unique project uses specified to enhance overall safety during construction activities.

The use of a LEO will be allowed at the contract cost only with the prior acceptance of the Engineer. The LEO shall not be used where the IMUTCD specifies flaggers shall be used.

REVISION TO SPECIAL PROVISION

801-R-672 LAW ENFORCEMENT OFFICER FOR WORK ZONE SAFETY

**LEO Personnel**

A LEO shall:

- a) Be an off-duty, non-Indiana State Police Law Enforcement Officer.
- b) Wear an official agency issued full police uniform with an agency issued badge. The uniform shall have the appropriate law enforcement department patches affixed.
- c) Be a graduate of an Indiana approved Law Enforcement Academy.
- d) Be a police officer or deputy actively employed by a law enforcement agency within Indiana.

**LEO Limitations**

The duties of an off-duty LEO hired under this special provision:

- a) shall be limited to those duties that the police officer normally performs while on active duty, and
- b) shall not include the duties of a:
  1. flagman, or
  2. security Officer.

**LEO Equipment**

LEO equipment shall include:

- a) The use of an official law enforcement agency issued vehicle with blue and red flashing lights.
- b) A radio or portable radio capable of accessing and communicating over the mutual aid channels within the area where the LEO is working.
- c) The necessary tools to issue citations and to process crashes and incidents within, and in a reasonable distance from, the work zone.
- d) The correct ANSI certified high-visibility safety apparel, provided by their agency, when the LEO is out of the agency issued vehicle.

**LEO Responsibilities**

A LEO shall:

- a) Be the sole occupant of the agency issued vehicle, unless otherwise directed by the Engineer.
- b) Report to the Contractor and the Engineer prior to the start of the operational shift to exchange contact information, obtain the placement location within the work zone, and discuss any additional specific work assignments.

REVISION TO SPECIAL PROVISION

801-R-672 LAW ENFORCEMENT OFFICER FOR WORK ZONE SAFETY

A LEO shall remain at the construction site for the duration of the assigned operational shift unless called to return to active duty. If a LEO has completed the specific work assignments, as described above, and time remains in the shift, the LEO may be directed to:

- a. be placed at a location for queue protection,
- b. provide enforcement focused on slowing traffic through the work zone, or
- c. patrol through the work zone, with flashing lights off.

At the end of the shift, the LEO shall notify the Contractor and the Engineer before leaving the construction site.

A LEO shall follow the procedures for infraction and ordinance violation enforcement established by IC 9-21-5-11 while working within the work zone, including issuing citations, written warnings, or verbal warnings for infractions. Detaining individuals in violation of traffic laws may also be an option, when and where appropriate.

A LEO's enforcement actions are encouraged to enhance motorist compliance and increase driver awareness. If a motorist's actions are considered reckless, or endangering workers or the motoring public, then pursuit of the motorist shall be appropriate.

A LEO shall respond to incidents including, but not be limited to, situations involving public safety, crashes, and answering emergency service calls within, and in a reasonable distance from the project limits to ensure the safety of the parties involved and the motoring public. ISP may be called if backup is necessary.

When a LEO is called to active duty by their agency and it becomes necessary for the LEO to leave the construction site, the LEO shall notify the Contractor and the Engineer as soon as possible.

It is the intent of the contract to provide effective use of LEO resources to work the construction zone by providing queue protection, reducing aggressive driving through speed enforcement, and patrolling the site. An officer's presence behind ~~barriades~~ a barrier wall is not an efficient use of the LEO resource.

When planning to work on contracts involving interstate operations, the LEO, in addition to the responsibilities described above, shall:

- a. Be responsible for indicating their interstate experience to the Contractor and the Engineer prior to the start of any project work zone shift involving interstate operations. If, in the opinion of the Engineer, the officer does not possess appropriate interstate experience, the officer shall not work the intended interstate shift.
- b. Communicate with the Indiana State Police, ISP, dispatch prior to the start of the operational shift to

REVISION TO SPECIAL PROVISION

801-R-672 LAW ENFORCEMENT OFFICER FOR WORK ZONE SAFETY

exchange contact information, placement location within the work zone, and any additional specific work assignments.

- c. Communicate with ISP at the end of an operational shift or if it becomes necessary to leave the construction site.

For interstate shifts, the LEO officer shall communicate with ISP through an ISP Dispatch radio channel or by cell phone. Proper radio etiquette, in accordance with 18 US Code §1464, shall be maintained at all times.

1. When the LEO has the ISP Dispatch radio channel on their radio, the LEO shall mark on at the start of the interstate operational shift. The LEO shall then monitor this channel for the duration of the shift and mark off at the end of the shift.
2. When the LEO does not have the appropriate ISP dispatch channel, the LEO shall contact the correct ISP dispatch center, by phone, for the work area. ISP Dispatch shall be provided with:
  - a. the LEO's name and contact number,
  - b. the LEO's planned work location, and
  - c. the LEO's interstate operational shift hours.

A list of ISP dispatch centers is located on the Department's Law Enforcement Officers for Work Zone Safety website located at:

<https://www.in.gov/indot/safety/work-zone-safety/law-enforcement-officers-for-work-zone-safety/>.

Once contacted, the ISP Dispatch operator will assign a mutual aid channel that is available on the LEO's radio.

The LEO shall monitor this assigned channel for the duration of the interstate operational shift. The LEO shall mark off the channel at the end of the shift.

The LEO shall use the ISP radio channel for interstate incident communications, to relay information, or to receive instructions and other information.

**Contractor Responsibilities**

The Contractor shall secure the services of a LEO with a police agency or private company capable of supplying officers that meet the requirements for a LEO as stated herein. If a private company is used, the Contractor shall enter into a subcontract agreement with the private company in accordance with 108.01. A subcontract agreement shall not be required if the LEO is obtained directly from a police agency. In either case, a Letter of Concurrence shall be required. A copy of the

REVISION TO SPECIAL PROVISION

801-R-672 LAW ENFORCEMENT OFFICER FOR WORK ZONE SAFETY

Letter of Concurrence is available on the Department's Law Enforcement Officers for Work Zone Safety website.

The Contractor shall:

- a) be responsible for securing, planning, placement, coordinating, and obtaining the acceptance of the Engineer for any selected LEO used for a project,
- b) be responsible for ensuring any selected LEO officer meets the personnel and equipment requirements listed herein,
- c) be responsible for the conduct and experience of any selected LEO in accordance with 108.07,
- d) maintain communications with the Engineer concerning all planned LEO activities, any issues that may arise, and when the LEO leaves the construction site for any reason,
- e) verify that the LEO remains at the construction site for the entire duration of the operational shift and reports back at the end of the shift, unless directed otherwise by the Engineer, and
- f) upon request, provide a copy of the subcontract agreement for the utilization and implementation of the LEO to the Engineer.
- g) obtain a Letter of Concurrence between the LEO and their agency and supply the Engineer with a copy of the Letter.

All planned duties and placement of the LEO will be subject to the acceptance of the Engineer.

The Contractor shall initiate and maintain communications with the LEO and the Engineer. The communications shall include the planning and coordination of the intended duties of the LEO. The Contractor and the LEO shall follow the placement of a LEO in work zones set forth by the Strategy for Law Enforcement in Work Zone Visor Card available on the Department's Law Enforcement Officers for Work Zone Safety Website located at:

<https://www.in.gov/indot/safety/work-zone-safety/law-enforcement-officers-for-work-zone-safety/>.

The Contractor shall establish direct communication with the LEO and the Engineer prior to the start of LEO operational shifts. The methods of communication shall be consistent for the contract and may include the exchange of mobile telephone numbers or dedicated communication devices such as mobile phones and walkie-talkies. The Contractor may provide the LEO with dedicated communication devices which shall be returned to the Contractor at the end of the LEO's shift.

REVISION TO SPECIAL PROVISION

801-R-672 LAW ENFORCEMENT OFFICER FOR WORK ZONE SAFETY

The Contractor shall have no authority over a LEO when the LEO is called away from the project and acting in an official law enforcement agency capacity not related to the contract.

**Engineer Responsibilities**

The Contractor's choice of activities and placement of a LEO associated with the project work zone shall be subject to the acceptance and direction of the Engineer, in accordance with 105 and 108.

The Engineer may direct a LEO to perform additional queue protection, enforcement, or other patrolling activities to encourage motorists to respect the work zone. Other activities of a LEO will not be allowed without prior acceptance of the Engineer.

The Engineer may request a copy of the subcontract agreement from the Contractor for the utilization and implementation of the LEO.

The Engineer will have no authority over a LEO when the LEO is called away from the project and acting in an official law enforcement agency capacity not related to the contract.

**Training**

Training for the LEO, the Contractor, and the Engineer will be conducted as stated herein.

**a) LEO Training:**

Any individual LEO designated to perform a work zone shift shall provide evidence acceptable to the Engineer of valid and successful completion of either Tier 1 or Tier 2 police academy training.

**b) Contractor and Engineer Training:**

The Contractor and the Engineer shall successfully complete the Department's Part 1 web based "Law Enforcement Officers in INDOT Work Zones Training" available on the Department's Law Enforcement Officers for Work Zone Safety website located at:

<https://www.in.gov/indot/safety/work-zone-safety/law-enforcement-officers-for-work-zone-safety/>.

**c) Additional Training**

In addition to the individual training listed above for each group, the LEO, the Contractor, and the Engineer shall review the Department's Part 2 Training and agree to adhere to the requirements contained in the specific training entitled "Instructions and Procedures For Non-ISP Law Enforcement Officers When Working in INDOT Work Zones".

All individuals shall sign the signature page located at the end of the Part 2 Training document. By signing, individuals will be confirming the successful completion of the individual training requirements and Part 2 of the law enforcement training.

The Part 2 training document is available on the Department's Law Enforcement Officers for Work Zone Safety website located at:

<https://www.in.gov/indot/safety/work-zone-safety/law-enforcement-officers-for-work-zone-safety/>.

REVISION TO SPECIAL PROVISION

801-R-672 LAW ENFORCEMENT OFFICER FOR WORK ZONE SAFETY

**Method of Measurement**

~~Law enforcement officer~~The use of a LEO for work zone safety will be measured by the number of hours during traffic control phases requiring a LEO and accepted by the Engineer. Each portion of an hour worked on an accepted shift will be measured as a whole hour.

If a LEO is directed, by their agency, to respond to a situation not related to the ~~contract~~project, the time away from the ~~contract~~project involved in responding to that situation will not be measured for payment.

~~Law enforcement officer~~ Training will not be measured for payment.

**Basis of Payment**

Law Enforcement Officers utilized for work zone safety will be paid for at the contract unit price of \$60.75 per hour for those hours accepted by the Engineer. Each portion of an hour worked on an accepted shift will be paid for as a whole hour.

~~Training shall be included in the cost of other items.~~

Payment will be made under:

<b>Pay Item</b>	<b>Pay Unit Symbol</b>
Law Enforcement Officer.....	HR

All costs associated with obtaining and implementing a qualified Law Enforcement Officer shall be included in the cost of the pay item.



APPROVED

COMMENTS AND ACTION

---

801-R-672 LAW ENFORCEMENT OFFICER FOR WORK ZONE SAFETY

DISCUSSION:

Mr. Pelz introduced and presented this item explaining that with a history of problematic implementation of Law Enforcement Officers, LEOs, on active Department contracts, there was a need to revise the current RSP 801-R-672 to help provide guidance and clarity.

Mr. Pelz proposed to revise the RSP with new procedures and training methods that will help provide officers for Department contracts that have appropriate training. The new process will also help the LEO's appointing authority with an acknowledgment of their officer's work area and use of police vehicles during Department operational shifts.

Following some questions and comments from Mr. Koch and industry, revisions have been incorporated, along with some minor editorial changes for clarification, and are shown in these minutes.

Mr. Pelz proposed to accept this item as revised.

Mr. Duncan, FHWA, asked about the subcontracting of the LEO. Mr. Pelz said yes, the sub needs to hire a LEO that has a regular job as a LEO and needs to be off duty. Ms. Borgmann responded that head hunting organizations go out and contact officers a lot of time. It's word by mouth so they can come and work for them for off duty hours. Ms. Reese from the Greenfield District provided further clarification as to how the District arranges for the use of LEOs on a contract, whether it is ISP or local. Mr. Pelz clarified that the officer still needs to meet the requirements stated in the RSP, and further information will be provided in the construction memo.

Ms. Borgmann expressed concerns regarding language about interstate aspects and reporting to ISP dispatch. Mr. Gulinson, ISP, responded that the Interstate shift aspect and reporting to ISP dispatch, I think that's off the premise that in almost all interstates around the state of Indiana, ISP dispatch would be handling as the primary agency in that particular area. And that's why it's pivotal that they contact ISP dispatch. I think when we start getting into some of our major US routes and State routes you start really opening Pandora's box because there's so many different municipalities and county agencies that handles all those areas as primary dispatch centers that I think if we're just trying to make sure there's good communication with ISP, the Interstates make complete sense to me. If we're looking to make sure they check in with the applicable dispatch center that is the primary.

Further discussion on the determination as to the hours needed for the LEOs and when, and how, to require them was addressed by Mr. Pelz, Mr. Kachler, Ms. Mouser, and Ms. Borgmann. Pelz said they can discuss those issue outside of the meeting and what is presented in this item will suffice for now, and let the area engineers make those determinations for now.

There was no further discussion and this item passed as revised.

[continued on the next page]

COMMENTS AND ACTION

801-R-672 LAW ENFORCEMENT OFFICER FOR WORK ZONE SAFETY

[continued]

<p>Motion: Mr. Pelz          Second: Mr. Boruff          Ayes: 10          Nays: 0          FHWA Approval: <u>YES</u></p>	<p><b>Action:</b>  <input type="checkbox"/> Passed as Submitted  <input checked="" type="checkbox"/> Passed as Revised  <input type="checkbox"/> Withdrawn</p>
<p>2026 Standard Specifications Sections:          NONE</p>	<p><input type="checkbox"/> 2028 Standard Specifications  <input checked="" type="checkbox"/> Revise Pay Items List (unit price)  <input type="checkbox"/> Notification to Designers if change is <u>not</u> addressed by RSP</p>
<p>Recurring Special Provisions or Plan Details:  <a href="#">801-R-672 LAW ENFORCEMENT OFFICER FOR WORK ZONE SAFETY</a></p>	<p><input type="checkbox"/> Create RSP (No. __)          Effective:</p>
<p>Standard Drawing affected:          NONE</p>	<p><input checked="" type="checkbox"/> Revise RSP (No. <u>801-R-672</u>)          Effective: <u>May 1, 2026</u></p>
<p>Design Manual Chapter:          NONE</p>	<p><input type="checkbox"/> Standard Drawing          Effective:</p>
<p>GIFE Section:          26.2</p>	<p><input type="checkbox"/> Create RPD (No. __)          Effective:</p>
	<p><input checked="" type="checkbox"/> GIFE Update (<u>Section 26</u>)  <input type="checkbox"/> Frequency Manual Update  <input type="checkbox"/> AWP Update</p>

PROPOSAL TO STANDARDS COMMITTEE

PROBLEM(S) ENCOUNTERED: Standard drawing series E 726-BEBP provides standard details for elastomeric bearing pads, but the load plates that are vulcanized to the pads may vary by project. Therefore, the final bearing assembly isn't currently standardized, and each project may require a unique bearing detail. This results in fabrication and construction inefficiencies.

PROPOSED SOLUTION: Revise standard drawing series E 726-BEBP to provide standard bearing plate, shim, and flange connection plate details for prestressed bulb-tee and wide flange prestressed bulb-tee beams. The new details will also facilitate field adjustment of shim thickness and future bearing replacement.

APPLICABLE STANDARD SPECIFICATIONS: Section 726 (no changes required)

APPLICABLE STANDARD DRAWING: E 726-BEBP series

APPLICABLE DESIGN MANUAL CHAPTER: IDM Chapter 409 – Abutment, Bent, Pier, and Bearing (changes forthcoming)

APPLICABLE SECTION OF GIFE: N/A

APPLICABLE RECURRING SPECIAL PROVISION OR PLAN DETAILS: RSP 726-B-328 (no changes required)

PAY ITEMS AFFECTED: N/A

APPLICABLE SUB-COMMITTEE ENDORSEMENT: INDOT/ASCE Structures Committee

IF APPROVED AS RECURRING SPECIAL PROVISION OR PLAN DETAILS, PROPOSED BASIS FOR USE:  
Contracts that contain 726 pay items.

IMPACT ANALYSIS (attach report):

Submitted By: Pete White

Title: Design Manager

Division: INDOT Bridge Engineering

E-mail: [pewwhite@indot.in.gov](mailto:pewwhite@indot.in.gov)

Date: December 22, 2025

IMPACT ANALYSIS REPORT CHECKLIST

*Explain the business case as to why this item should be presented to the Standards Committee for approval. Answer the following questions with Yes, No or N/A.*

Does this item appear in any other specification sections? No

Will approval of this item affect the Qualified Products List (QPL)? No

Will this proposal improve:

Construction costs? Yes

Construction time? Yes

Customer satisfaction? No

Congestion/travel time? No

Ride quality? No

Will this proposal reduce operational costs or maintenance effort? No

Will this item improve safety:

For motorists? No

For construction workers? No

Will this proposal improve quality for:

Construction procedures/processes? Yes

Asset preservation? Yes

Design process? Yes

Will this change provide the contractor more flexibility? No

Will this proposal provide clarification for the Contractor and field personnel? No

Can this item improve/reduce the number of potential change orders? No

Is this proposal needed for compliance with:

Federal or State regulations? No

AASHTO or other design code? No

Is this item editorial? No

Provide any further information as to why this proposal should be placed on the Standards Committee meeting Agenda:

REVISION TO STANDARD DRAWINGS

E 726-BEBP-01 BRIDGE ELASTOMERIC BEARING PADS (WITH MARKUPS)

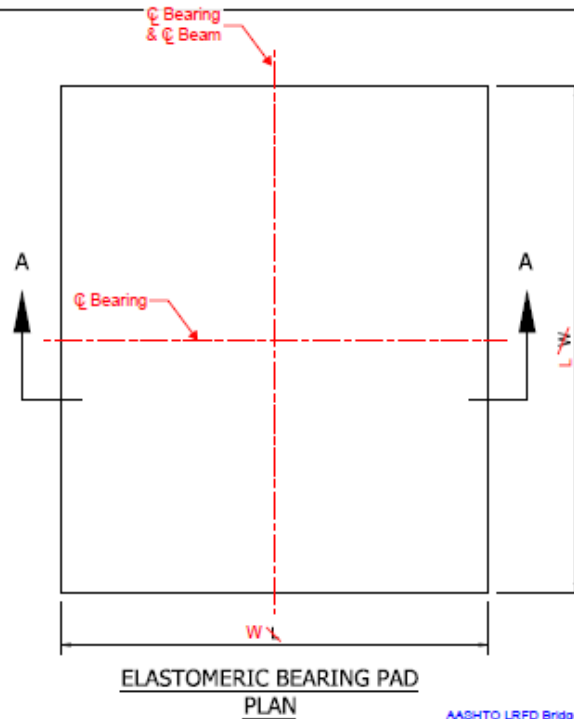

**NOTES:**

- ~~1. The rectangular Elastomeric Bearing Pad shall be placed with L dimension parallel to longitudinal bridge axis.~~
- ① 2.  $h_{vt}$  is defined as the summation of all internal elastomer thickness plus the two external layers thickness.

**TABLE OF DIMENSIONS**

Bearing Designation	Bearing Width W	Bearing Length L	Number of Internal Elastomer Layers n	$h_{vt}$ ①	Number of Steel Shims $n_s$	Bearing Total Thickness H
TYPE 1	14"	10 1/2"	3	2 1/16"	4	2 15/32"
TYPE 2	14"	11 1/2"	4	2 9/16"	5	3 3/32"
TYPE 3	18"	11"	4	2 9/16"	5	3 3/32"
TYPE 4	24"	12"	5	3 1/16"	6	3 11/16"
TYPE 5A	22"	11"	4	2 9/16"	5	3 3/32"
TYPE 6A	22"	10"	4	2 9/16"	5	3 3/32"
TYPE 7A	22"	9"	3	2 1/16"	4	2 15/32"
TYPE 5B	12"	12"	4	2 9/16"	5	3 3/32"
TYPE 6B	12"	11"	4	2 9/16"	5	3 3/32"
TYPE 7B	12"	10"	3	2 1/16"	4	2 15/32"

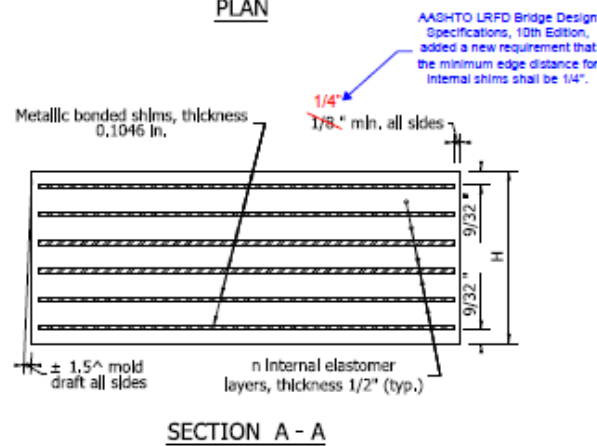

Note: Sheet 01 was added to include an index of all sheets in this series.

**INDIANA DEPARTMENT OF TRANSPORTATION**  
**BRIDGE ELASTOMERIC BEARING PADS**  
**TYPE 1 to 7**  
**FOR PRESTRESSED I-BEAMS & BOX BEAMS**  
 SEPTEMBER 2009-2026 02

STANDARD DRAWING NO. E 726-BEBP-01

	<del>/s/ Richard L. VonCleave</del> 09/01/09 DESIGN STANDARDS ENGINEER DATE
	<del>/s/ Mark A. Miller</del> 09/01/09 CHIEF HIGHWAY ENGINEER DATE

DESIGN STANDARDS ENGINEER

REVISION TO STANDARD DRAWINGS

E 726-BEBP-02 BRIDGE ELASTOMERIC BEARING PADS (WITH MARKUPS)

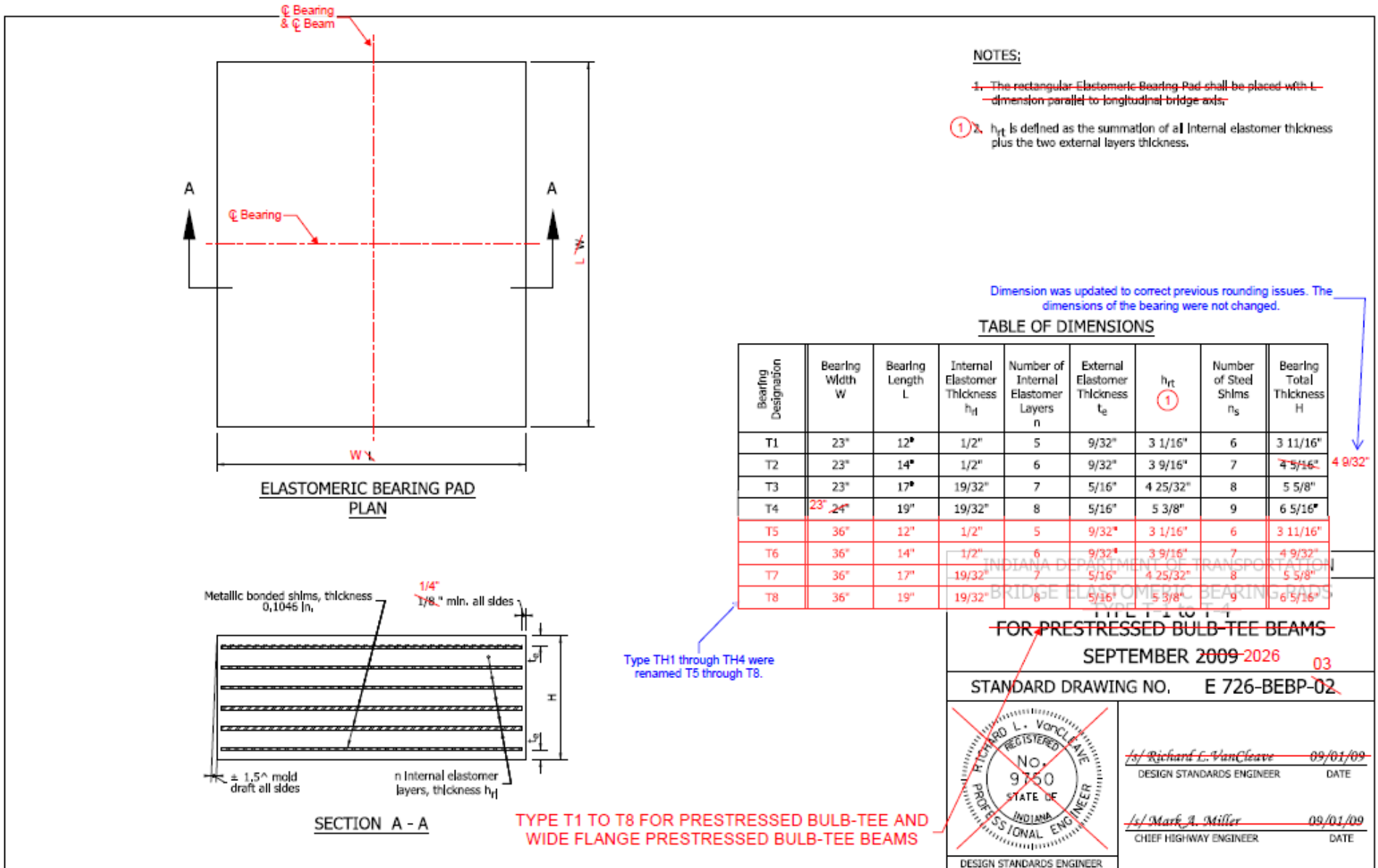

REVISION TO STANDARD DRAWINGS

E 726-BEBP-03 BRIDGE ELASTOMERIC BEARING PADS (WITH MARKUPS)

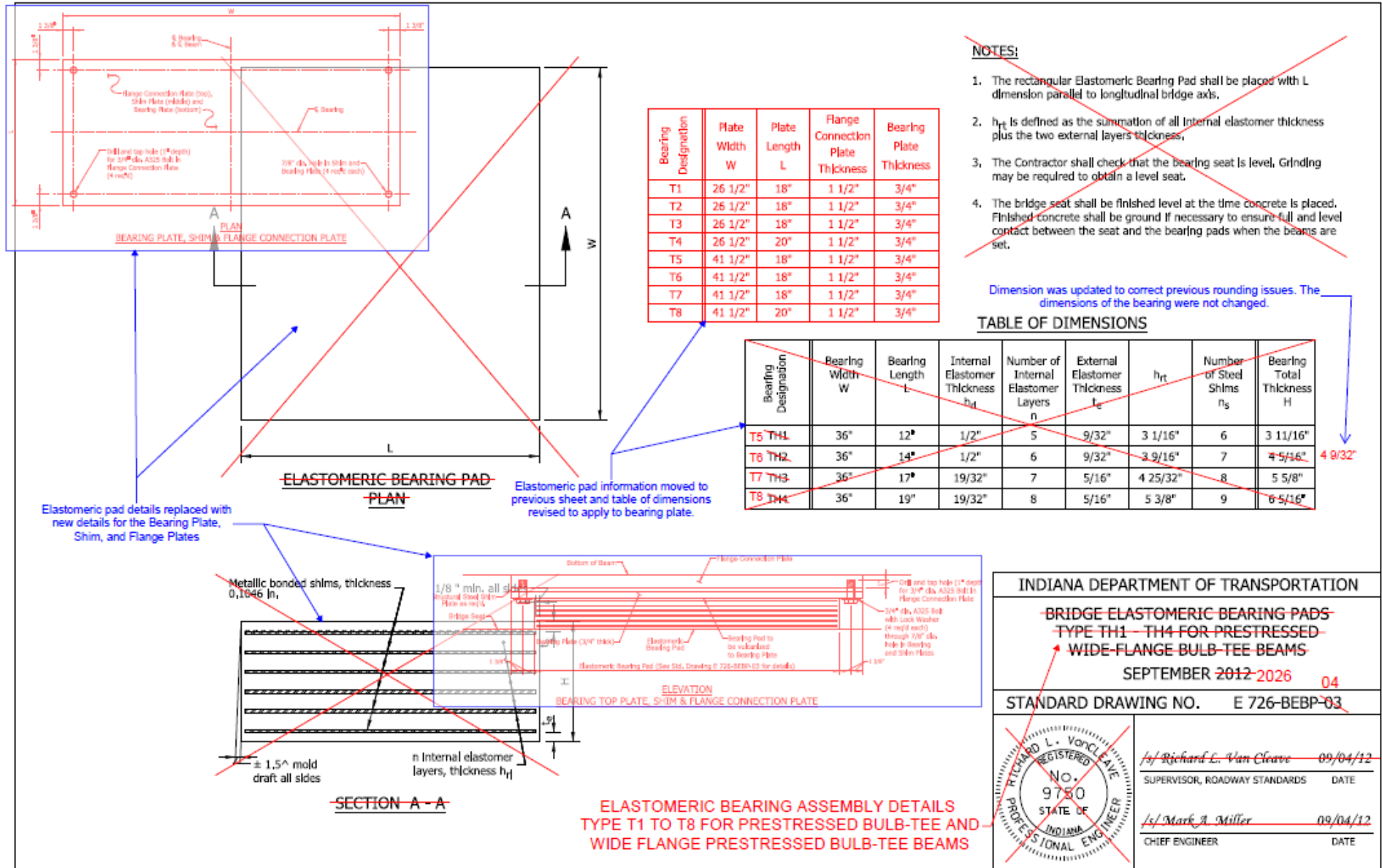



REVISION TO STANDARD DRAWINGS

E 726-BEBP-05 BRIDGE ELASTOMERIC BEARING PADS (WITH MARKUPS)

TABLE OF DIMENSIONS - TYPE S BEARINGS FOR STEEL BEAMS

Bearing Designation	Bearing Width W	Bearing Length L	Number of Internal Elastomer Layers n	h <sub>rt</sub> ①	Number of Steel Shims ns	Bearing Total Thickness H
S1-A	11"	8"	2	1 9/16"	3	1 7/8"
S1-B	11"	8"	3	2 1/16"	4	2 15/32"
S2-A	12"	9"	2	1 9/16"	3	1 7/8"
S2-B	12"	9"	3	2 1/16"	4	2 15/32"
S3-A	13"	10"	3	2 1/16"	4	2 15/32"
S3-B	13"	10"	4	2 9/16"	5	3 3/32"
S4-A	15"	11"	4	2 9/16"	5	3 3/32"
S4-B	15"	11"	5	3 1/16"	6	3 11/16"
S5-A	16"	12"	4	2 9/16"	5	3 3/32"
S5-B	16"	12"	5	3 1/16"	6	3 11/16"
S6-A	20"	13"	5	3 1/16"	6	3 11/16"
S6-B	20"	13"	6	3 9/16"	7	4 0/32"
S7-A	20"	15"	6	3 9/16"	7	4 0/32"
S7-B	20"	15"	7	4 1/16"	8	4 29/32"

These dimensions were updated to correct previous rounding issues. The dimensions of the bearings were not changed.

NOTES

- ① h<sub>rt</sub> is defined as the summation of all internal elastomer thicknesses plus the external elastomer thicknesses.
2. See Standard Drawing E 726-BEBP-04 for Type S bearing assembly details.
- ③ Equivalent rolled angle shape with stiffeners may be used in lieu of welded plates.

Detail A moved here from previous sheet and Anchor Bolt Assembly detail added.

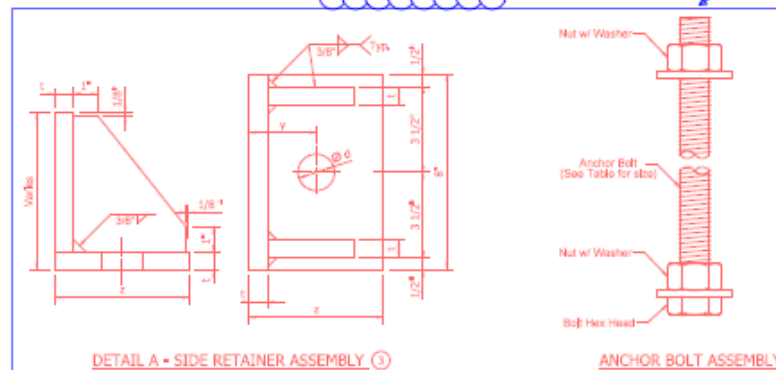

INDIANA DEPARTMENT OF TRANSPORTATION

ELASTOMERIC BEARING PADS  
TYPE S

SEPTEMBER 2012-2026 06

STANDARD DRAWING NO. E 726-BEBP-05

~~RICHARD L. VAN CLEAVE~~  
 REGISTERED  
 No. 9750  
 STATE OF INDIANA  
 PROFESSIONAL ENGINEER

~~/s/ Richard L. Van Cleave~~ 09/04/12  
 SUPERVISOR, ROADWAY STANDARDS DATE

~~/s/ Mark A. Miller~~ 09/04/12  
 CHIEF ENGINEER DATE

REVISION TO STANDARD DRAWINGS

E 726-BEBP-01 BRIDGE ELASTOMERIC BEARING PADS (REVISED DRAFT)

INDEX	
SHEET NO.	SUBJECT
1	Bridge Elastomeric Bearing Pads Index
2	Bridge Elastomeric Bearing Pads Type 1 to 7 for Prestressed I-Beams and Box Beams
3	Bridge Elastomeric Bearing Pads Type T1 to TH4 for Prestressed Bulb-Tee and Wide Flange Prestressed Bulb-Tee Beams
4	Elastomeric Bearing Assembly Details for Type T1 to TH4 for Prestressed Bulb-Tee and Wide Flange Prestressed Bulb-Tee Beams
5	Bridge Elastomeric Bearing Pads Type S for Steel Beams
6	Elastomeric Bearing Assembly Details for Type S for Steel Beams

INDIANA DEPARTMENT OF TRANSPORTATION	
BRIDGE ELASTOMERIC BEARING PADS INDEX SEPTEMBER 2026	
STANDARD DRAWING NO. E 726-BEBP-01	
	DESIGN STANDARDS ENGINEER DATE
	CHIEF ENGINEER DATE

REVISION TO STANDARD DRAWINGS

E 726-BEBP-02 BRIDGE ELASTOMERIC BEARING PADS (PROPOSED DRAFT)

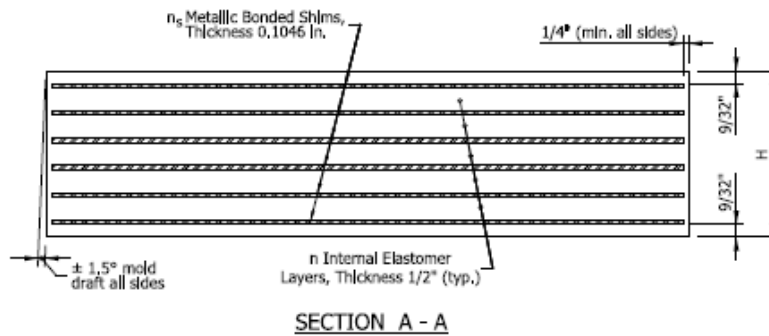
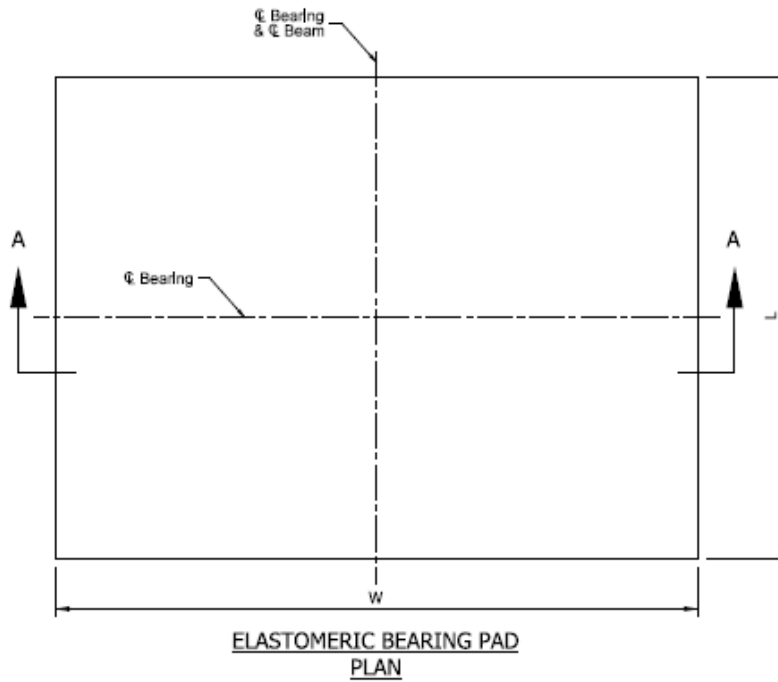

**NOTES:**

- ①  $h_{rt}$  is defined as the summation of all internal elastomer thicknesses plus the thickness of the two external layers.

**TABLE OF DIMENSIONS**

Bearing Designation	Bearing Width W	Bearing Length L	Number of Internal Elastomer Layers n	$h_{rt}$ ①	Number of Steel Shims $n_s$	Bearing Total Thickness H
TYPE 1	14"	10 1/2"	3	2 1/16"	4	2 15/32"
TYPE 2	14"	11 1/2"	4	2 9/16"	5	3 3/32"
TYPE 3	18"	11"	4	2 9/16"	5	3 3/32"
TYPE 4	24"	12"	5	3 1/16"	6	3 11/16"
TYPE 5A	22"	11"	4	2 9/16"	5	3 3/32"
TYPE 6A	22"	10"	4	2 9/16"	5	3 3/32"
TYPE 7A	22"	9"	3	2 1/16"	4	2 15/32"
TYPE 5B	12"	12"	4	2 9/16"	5	3 3/32"
TYPE 6B	12"	11"	4	2 9/16"	5	3 3/32"
TYPE 7B	12"	10"	3	2 1/16"	4	2 15/32"

INDIANA DEPARTMENT OF TRANSPORTATION

BRIDGE ELASTOMERIC BEARING PADS  
 TYPE 1 to 7  
 FOR PRESTRESSED I-BEAMS AND BOX BEAMS  
 SEPTEMBER 2026

STANDARD DRAWING NO. E 726-BEBP-02

DESIGN STANDARDS ENGINEER DATE

CHIEF ENGINEER DATE

REVISION TO STANDARD DRAWINGS

E 726-BEBP-03 BRIDGE ELASTOMERIC BEARING PADS (REVISED DRAFT)

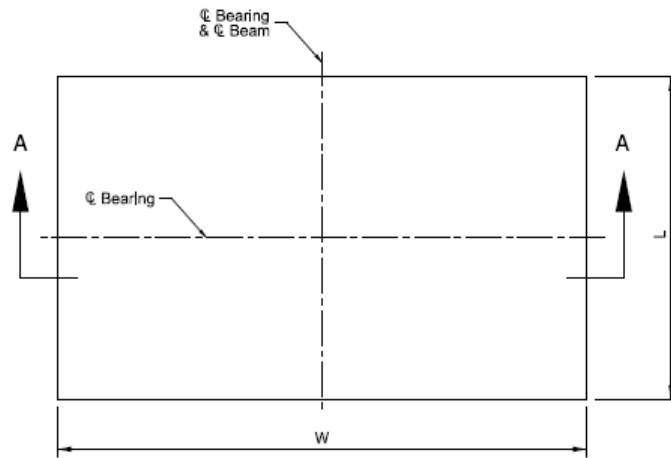

ELASTOMERIC BEARING PAD  
 PLAN

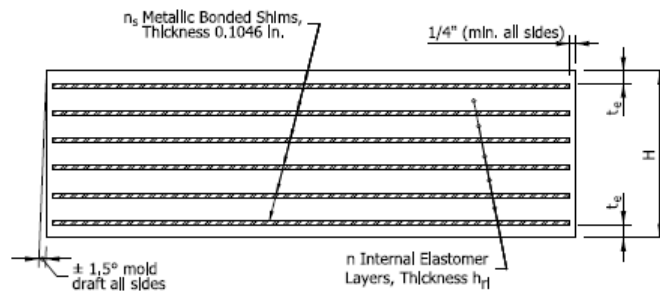

SECTION A - A

NOTES:

- ①  $h_{IT}$  is defined as the summation of all internal elastomer thicknesses plus the thickness of the two external layers.

TABLE OF DIMENSIONS

Bearing Designation	Bearing Width W	Bearing Length L	Internal Elastomer Thickness $h_{II}$	Number of Internal Elastomer Layers n	External Elastomer Thickness $t_e$	$h_{IT}$ ①	Number of Steel Shims $n_s$	Bearing Total Thickness H
T1	23"	12"	1/2"	5	9/32"	3 1/16"	6	3 11/16"
T2	23"	14"	1/2"	6	9/32"	3 9/16"	7	4 9/32"
T3	23"	17"	19/32"	7	5/16"	4 25/32"	8	5 5/8"
T4	23"	19"	19/32"	8	5/16"	5 3/8"	9	6 5/16"
TH1	36"	12"	1/2"	5	9/32"	3 1/16"	6	3 11/16"
TH2	36"	14"	1/2"	6	9/32"	3 9/16"	7	4 9/32"
TH3	36"	17"	19/32"	7	5/16"	4 25/32"	8	5 5/8"
TH4	36"	19"	19/32"	8	5/16"	5 3/8"	9	6 5/16"

INDIANA DEPARTMENT OF TRANSPORTATION  
 BRIDGE ELASTOMERIC BEARING PADS  
 TYPE T1 to TH4 FOR PRESTRESSED BULB-TEE AND  
 WIDE FLANGE PRESTRESSED BULB-TEE BEAMS  
 SEPTEMBER 2026

STANDARD DRAWING NO. E 726-BEBP-03

DESIGN STANDARDS ENGINEER DATE

CHIEF ENGINEER DATE

REVISION TO STANDARD DRAWINGS

E 726-BEBP-04 BRIDGE ELASTOMERIC BEARING PADS (REVISED DRAFT)

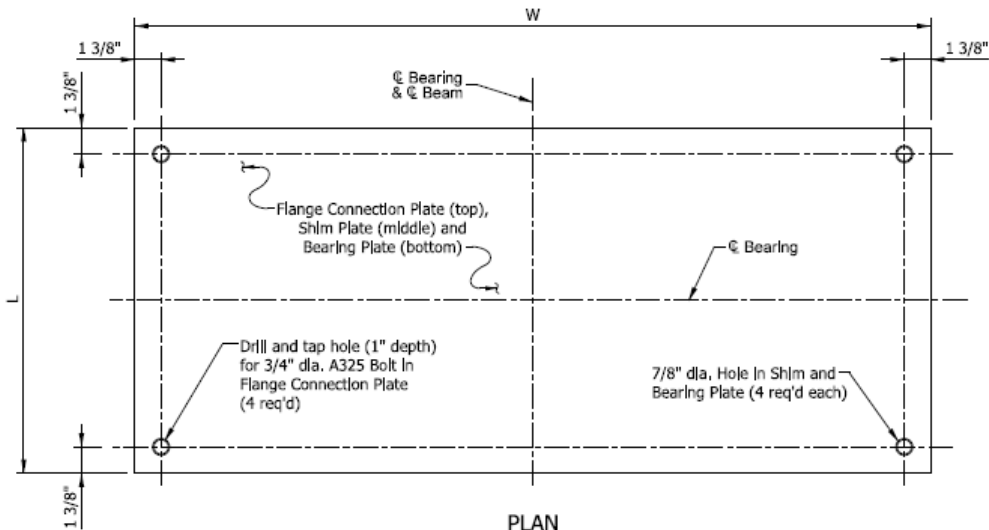

PLAN  
 BEARING PLATE, SHIM & FLANGE CONNECTION PLATE

TABLE OF DIMENSIONS

Bearing Designation	Plate Width W	Plate Length L	Flange Connection Plate Thickness	Bearing Plate Thickness
T1	28 1/2"	18"	1 1/2"	3/4"
T2	28 1/2"	18"	1 1/2"	3/4"
T3	28 1/2"	18"	1 1/2"	3/4"
T4	28 1/2"	20"	1 1/2"	3/4"
TH1	41 1/2"	18"	1 1/2"	3/4"
TH2	41 1/2"	18"	1 1/2"	3/4"
TH3	41 1/2"	18"	1 1/2"	3/4"
TH4	41 1/2"	20"	1 1/2"	3/4"

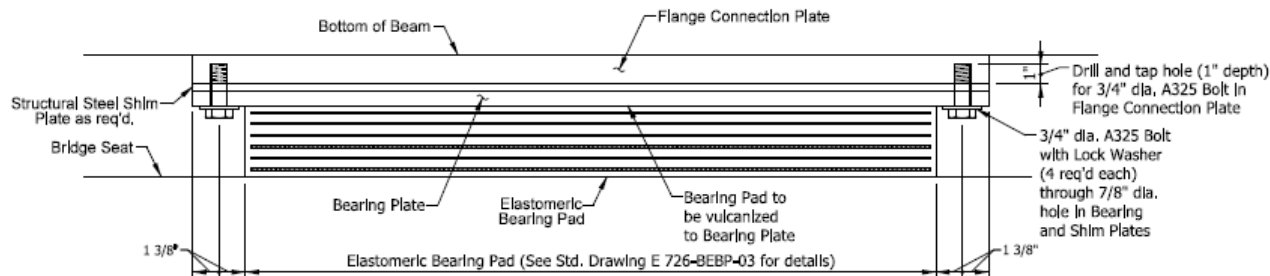

ELEVATION  
 BEARING TOP PLATE, SHIM & FLANGE CONNECTION PLATE

INDIANA DEPARTMENT OF TRANSPORTATION

ELASTOMERIC BEARING ASSEMBLY DETAILS  
 TYPE T1 to TH4 FOR PRESTRESSED BULB-TEE AND  
 WIDE FLANGE PRESTRESSED BULB-TEE BEAMS  
 SEPTEMBER 2026

STANDARD DRAWING NO. E 726-BEBP-04

DESIGN STANDARDS ENGINEER	DATE
CHIEF ENGINEER	DATE

REVISION TO STANDARD DRAWINGS

E 726-BEBP-05 BRIDGE ELASTOMERIC BEARING PADS (PROPOSED DRAFT)

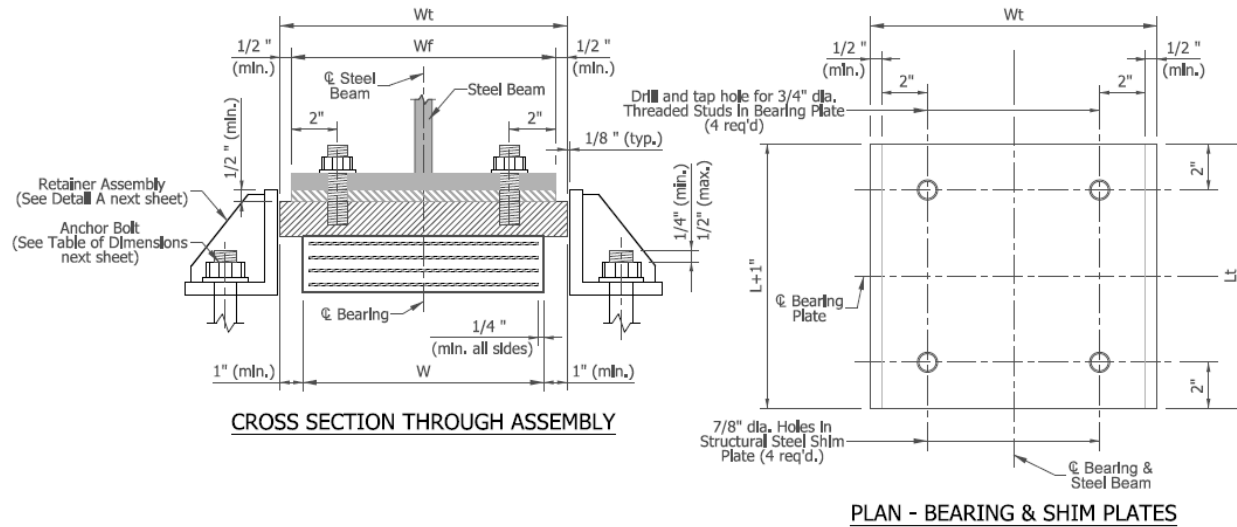

**NOTES:**

1. The bearing plate size shall be calculated as follows:  
 $L_t = L + 1"$ ;  $W_t = W_f + 1"$  or  $W_t = W + 2"$  whichever is greater.
2. Minimum dimension required is  $1\ 1/2"$  + flange thickness + shim thickness.
3. Minimum thickness  $1\ 1/2"$ .
4. See standard drawing E 726-BEBP-06 for Table of Dimensions and Detail A.

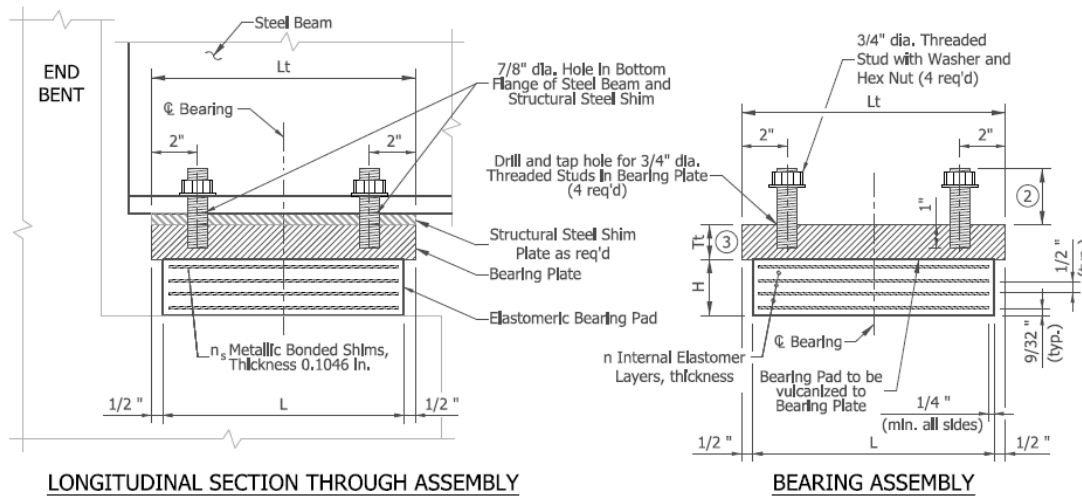

INDIANA DEPARTMENT OF TRANSPORTATION	
BRIDGE ELASTOMERIC BEARING PADS TYPE S FOR STEEL BEAMS	
SEPTEMBER 2026	
STANDARD DRAWING NO.	E 726-BEBP-05
DESIGN STANDARDS ENGINEER	DATE
CHIEF ENGINEER	DATE

REVISION TO STANDARD DRAWINGS

E 726-BEBP-06 BRIDGE ELASTOMERIC BEARING PADS (PROPOSED DRAFT)

TABLE OF DIMENSIONS - TYPE S BEARINGS FOR STEEL BEAMS

Bearing Designation	Bearing Width W	Bearing Length L	Number of Internal Elastomer Layers n	h <sub>IT</sub> ①	Number of Steel Shlms n <sub>s</sub>	Bearing Total Thickness H	Side Retainer Assembly				
							Anchor Bolt Size	Dimensions			
								y	z	t	Ø d
S1-A	11"	8"	2	1 9/16"	3	1 7/8"	1" x 12"	2 1/8"	4"	1/2"	1 1/8"
S1-B	11"	8"	3	2 1/16"	4	2 15/32"					
S2-A	12"	9"	2	1 9/16"	3	1 7/8"					
S2-B	12"	9"	3	2 1/16"	4	2 15/32"					
S3-A	13"	10"	3	2 1/16"	4	2 15/32"	1 1/4" x 15"	2 1/4"	4 3/4"	1/2"	1 3/8"
S3-B	13"	10"	4	2 9/16"	5	3 3/32"					
S4-A	15"	11"	4	2 9/16"	5	3 3/32"					
S4-B	15"	11"	5	3 1/16"	6	3 11/16"					
S5-A	16"	12"	4	2 9/16"	5	3 3/32"	1 1/2" x 18"	2 3/4"	5 1/2"	3/4"	1 5/8"
S5-B	16"	12"	5	3 1/16"	6	3 11/16"					
S6-A	20"	13"	5	3 1/16"	6	3 11/16"					
S6-B	20"	13"	6	3 9/16"	7	4 9/32"					
S7-A	20"	15"	6	3 9/16"	7	4 9/32"	1 1/2" x 18"	2 3/4"	5 1/2"	3/4"	1 5/8"
S7-B	20"	15"	7	4 1/16"	8	4 29/32"					

NOTES:

- ① h<sub>IT</sub> is defined as the summation of all internal elastomer thicknesses plus the thickness of the two external layers.
2. See Standard Drawing E 726-BEBP-05 for Type S bearing assembly details.
- ③ Equivalent rolled angle shape with stiffeners may be used in lieu of welded plates.

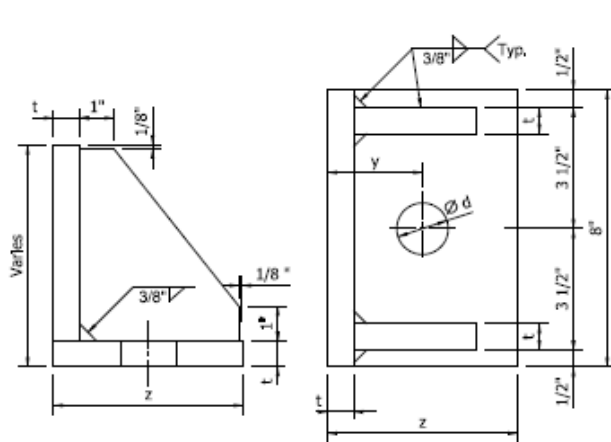

DETAIL A - SIDE RETAINER ASSEMBLY ③

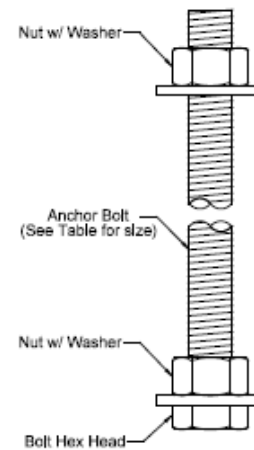

ANCHOR BOLT ASSEMBLY

INDIANA DEPARTMENT OF TRANSPORTATION	
ELASTOMERIC BEARING ASSEMBLY DETAILS FOR TYPE S FOR STEEL BEAMS SEPTEMBER 2026	
STANDARD DRAWING NO. E 726-BEBP-06	
DESIGN STANDARDS ENGINEER	DATE
CHIEF ENGINEER	DATE

COMMENTS AND ACTION

E 726-BEBP series BRIDGE ELASTOMERIC BEARING PADS

DISCUSSION:

This item was introduced and presented by Mr. White who stated that standard drawing series E 726-BEBP provides standard details for elastomeric bearing pads, but the load plates that are vulcanized to the pads may vary by project. Therefore, the final bearing assembly isn't currently standardized, and each project may require a unique bearing detail. This results in fabrication and construction inefficiencies.

Mr. White proposed to revise standard drawing series E 726-BEBP to provide standard bearing plate, shim, and flange connection plate details for prestressed bulb-tee and wide flange prestressed bulb-tee beams. The new details will also facilitate field adjustment of shim thickness and future bearing replacement.

There were no further discussions and this item passed as submitted.

Post-meeting: editorial changes made to E 726-BEBP-01, -03, and -04 are shown in these minutes.

These edits were received from the sponsor of this item, Mr. White, and consist of changing some naming conventions and correcting some dimensions, as shown highlighted.

<p>Motion: Mr. White                  Second: Mr. Novak                  Ayes: 10                  Nays: 0                  FHWA Approval: <u>YES</u></p>	<p><u>Action:</u>  <input checked="" type="checkbox"/> Passed as Submitted  <input type="checkbox"/> Passed as Revised  <input type="checkbox"/> Withdrawn</p>
<p>2026 Standard Specifications Sections:                  Section 726 (no changes required)</p>	<p><input type="checkbox"/> 2028 Standard Specifications  <input type="checkbox"/> Revise Pay Items List  <input type="checkbox"/> Notification to Designers if change is <u>not</u>                  addressed by RSP</p>
<p>Recurring Special Provisions or Plan                  Details:                  RSP 726-B-328 (no changes required)</p>	<p><input type="checkbox"/> Create RSP (No. __)                  Effective:</p>
<p>Standard Drawing affected:                  E 726-BEBP series</p>	<p><input type="checkbox"/> Revise RSP (No. __)                  Effective:</p>
<p>Design Manual Chapter:                  IDM Chapter 409 – Abutment, Bent, Pier,                  and Bearing (changes forthcoming)</p>	<p><input checked="" type="checkbox"/> Standard Drawing <u>E 726-BEBP series</u>                  Effective: <u>September 1, 2026</u></p>
<p>GIFE Section:                  NONE</p>	<p><input type="checkbox"/> Create RPD (No. __)                  Effective:  <input type="checkbox"/> GIFE Update  <input type="checkbox"/> Frequency Manual Update  <input type="checkbox"/> AWP Update</p>